

NOTE:  
Please read all instructions  
carefully before using this  
product

Table of Contents

Safety Notice

Important Assembly  
Information

Care and Maintenance

Parts List

Warranty

Ordering Parts

Model  
PM-4400

Retain This  
Manual for  
Reference

110509

**OWNER'S  
MANUAL**

**IMPEX**  
FITNESS PRODUCTS

**MARCY<sup>®</sup> PRO  
COMPACT GYM  
PM-4400**

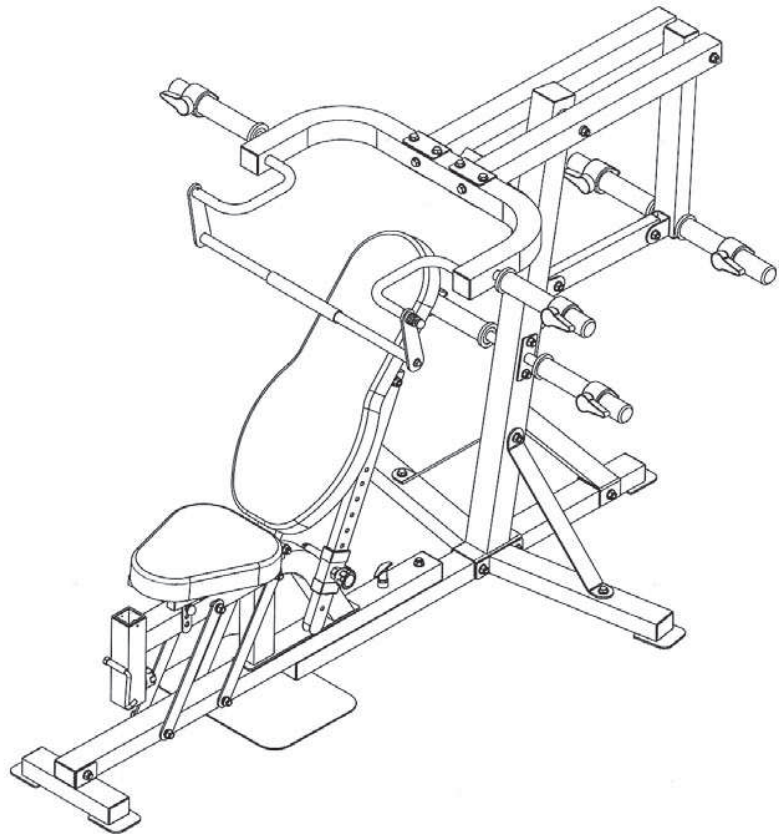

**IMPORTANT:** Please read this manual before commencing  
assembly of this product.

**IMPEX<sup>®</sup> INC.**

14777 DON JULIAN RD., CITY OF INDUSTRY, CA 91746

Tel: (800) 999-8899 Fax: (626) 961-9966

[www.impex-fitness.com](http://www.impex-fitness.com)

[info@impex-fitness.com](mailto:info@impex-fitness.com)

---

## TABLE OF CONTENTS

BEFORE YOU BEGIN.....	1
IMPORTANT SAFETY NOTICES.....	2
EXERCISE GUIDELINES.....	3
WARNING LABEL PLACEMENT.....	5
IMPORTANT ASSEMBLY INFORMATION.....	6
CARE AND MAINTANENCE, WEIGHT CAPACITY, OPERATING NOTES.....	7
PARTS LIST.....	8
EXPLODED DIAGRAM.....	10
WARRANTY.....	11
ORDERING PARTS.....	11

---

## BEFORE YOU BEGIN

Thank you for selecting the MARCY PRO PM-4400 Compact Gym by IMPEX<sup>®</sup> INC. For your safety and benefit, read this manual carefully before using the equipment. As a manufacturer, we are committed to provide you complete customer satisfaction. If you have any questions, or find there are missing or damaged parts, we guarantee you complete satisfaction through direct assistance from our factory. To avoid unnecessary delays, *please call our TOLL-FREE customer service number*. Our Customer Service Agents will provide immediate assistance to you.

**Toll-Free Customer Service Number**

**1-800-999-8899**

**Mon. – Fri. 9 a.m. – 5 p.m. PST**

**[www.impex-fitness.com](http://www.impex-fitness.com)**

**[info@impex-fitness.com](mailto:info@impex-fitness.com)**

## IMPORTANT SAFETY NOTICE

This exercise equipment is built for optimum safety. However, certain precautions apply whenever you operate a piece of exercise equipment. Be sure to read the entire manual before you assemble or operate your equipment. In particular, note the following safety precautions:

1. **Keep children and pets away from the equipment at all times. DO NOT leave children unattended in the same room with the equipment.**
2. Only one person at a time should use the equipment.
3. If the user experiences dizziness, nausea, chest pain, or any other abnormal symptoms, STOP the workout at once. CONSULT A PHYSICIAN IMMEDIATELY.
4. Position the equipment on a clear, leveled surface. DO NOT use the equipment near water or outdoors.
5. Keep hands away from all moving parts.
6. Always wear appropriate workout clothing when exercising. DO NOT wear robes or other clothing that could become caught in the equipment. Running or aerobic shoes are also required when using the equipment.
7. Use the equipment only for its intended use as described in this manual. DO NOT use attachments not recommended by the manufacturer.
8. Do not place any sharp object around the equipment.
9. Disabled person should not use the equipment.
10. Before using the equipment to exercise, always do stretching exercises to properly warm up.
11. Never operate the equipment if the equipment is not functioning properly.
12. A spotter is recommended during exercise.
13. **This equipment is designed and intended for home and consumer use only, not for commercial use.**

**WARNING: BEFORE BEGINNING ANY EXERCISE PROGRAM, CONSULT YOUR PHYSICIAN. THIS IS ESPECIALLY IMPORTANT FOR INDIVIDUALS OVER THE AGE OF 35 OR PERSONS WITH PRE-EXISTING HEALTH PROBLEMS. READ ALL INSTRUCTIONS BEFORE USING ANY FITNESS EQUIPMENT. IMPEX INC. ASSUMES NO RESPONSIBILITY FOR PERSONAL INJURY OR PROPERTY DAMAGE SUSTAINED BY OR THROUGH THE USE OF THIS PRODUCT.**

**SAVE THESE INSTRUCTIONS.**

## **EXERCISE GUIDELINES**

### ***Building Muscle and Gaining Weight***

Unlike aerobic exercise, which emphasizes endurance training, anaerobic exercise focuses on strength training. A gradual weight gain can occur while building the size and strength of muscles. While developing muscle mass, your body adapts to the stress placed upon it. You can modify your diet to include foods such as meat, fish and vegetables. These foods help muscles recover and replenish important nutrients after a strenuous workout.

### ***Muscle Strength and Endurance***

To achieve the greatest benefit from exercise, it is important to develop an exercise program that allows you to work all of the major muscle groups equally.

To increase muscles strength; follow this principle:

Increasing resistance and maintaining the number of repetitions of an exercise results in increased muscle strength.

To tone your body, follow the principle: Decreasing resistance plus increasing the number of repetitions of an exercise results in increased body tone.

Once you feel comfortable with an exercise, you can change the resistance, the number of repetitions, or the speed at which you do the exercise. It is not necessary to change all three variables. For example, let's say that you are training at 50 lbs and performing the exercise 10 times in 3 minutes. When this becomes too easy, you may decide to move up lifting 60 lbs for the same number of repetitions in the same amount of time. Lifting more weights fewer times most often develops muscle strength. To gain both muscle strength and endurance, it is recommended that you perform each exercise 15 to 20 reps per set.

### ***Training Intensity***

How hard you begin to train depends on your overall level of fitness. The soreness you experienced can be lessened by decreasing the load you place on your muscles and by performing fewer sets. To avoid injury, you should gradually work into an exercise program and set the load to your individual fitness level. The load should increase as your fitness level increases.

Muscle soreness is common, especially when you first start exercising. If you are painfully sore for a long time, it may be time to change your program. Eventually, your muscle system will become accustomed to the stress and strain placed on it.

## ***Beginning a Strength Building Program***

### ***Warming Up***

To begin strength training, it is important to stretch and perform light exercise for 5 to 10 minutes. This helps prepare the body for more strenuous exercise by increasing circulation, raising your body temperature and developing more oxygen to your muscles.

### ***Workout***

Each workout to keep in mind that muscle soreness that lasts for a long period is not desirable and may mean that injury has occurred.

### ***Cool Down***

At the end of each workout, perform slow stretching exercises for 5 to 10 minutes. Ease into each stretch only going as far as you can. This stage allows your muscles wind down after training.

To provide a total workout program it is also recommended that 2 to 3 days of aerobic exercise is performed in addition to the strength training.

### ***Drinking Water***

For the body to function properly, it must be properly hydrated. If you are exercising, you should increase your fluid intake. The reason for this is that the water you take in will leave your system through the sweating mechanism that cools your body during exercise. The water you lose through exercise must be replaced so that the muscles can recover properly.

### ***Rest Day***

Although you may not feel like doing it, taking a rest day at least once a week is important because it gives your body a chance to heal itself. Continuously working your muscle will result in over training which will not benefit in the long run.

## WARNING LABEL PLACEMENT

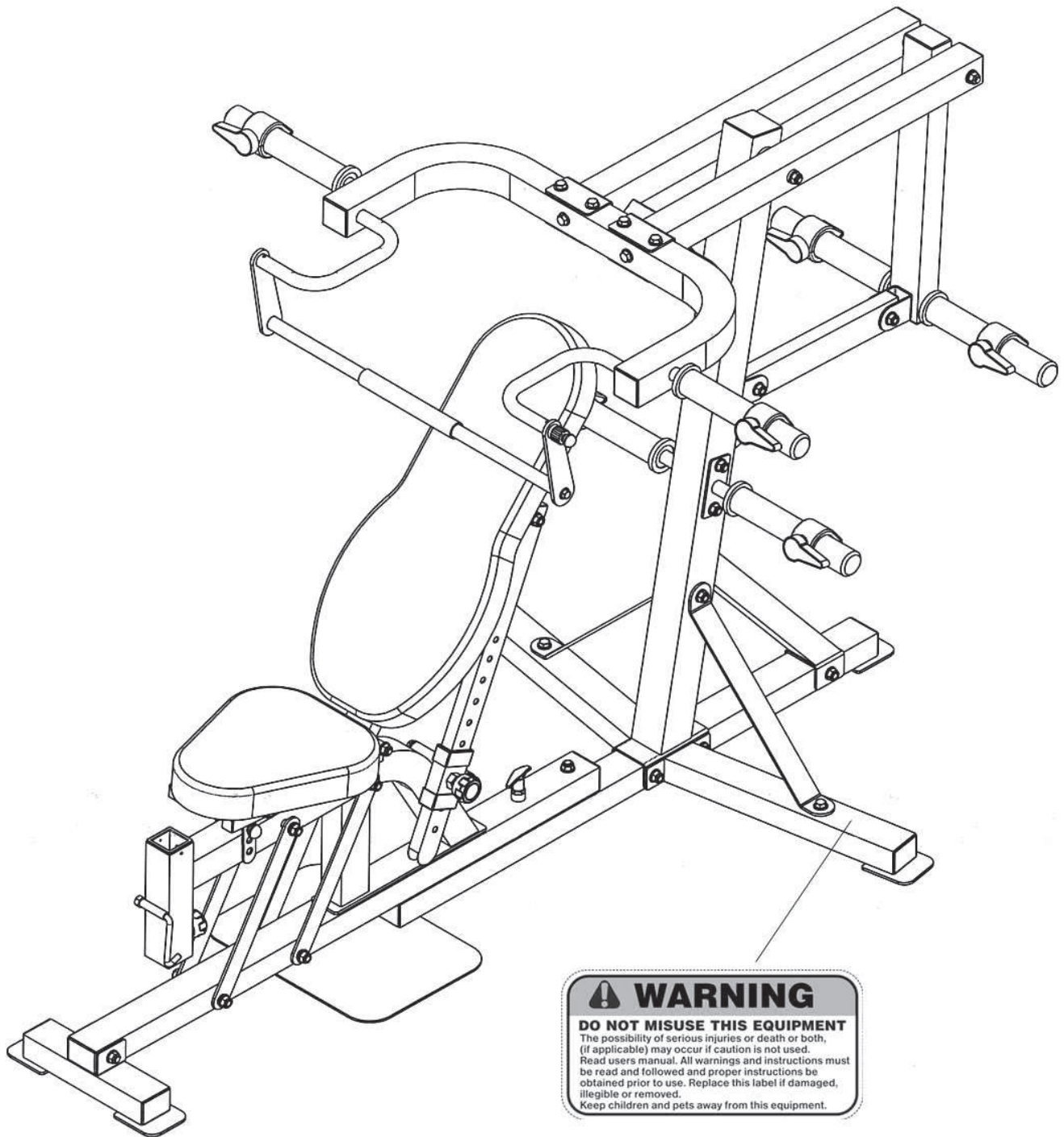

The warning labels shown here have been placed on the Base Frame. If the labels are missing or illegible, please call customer service at 1-800-888-8899 for replacements. Apply the labels in the location shown.

## IMPORTANT ASSEMBLY INFORMATION

- ❖ Tools Required for assembling the equipment: Two Adjustable Wrenches and Allen Wrenches.
- ❖ NOTE: It is strongly recommended that this equipment is assembled by two or more people to avoid possible injury.
- ❖ Ensure **Carriage Bolts** are inserted through the **SQUARE holes** on components that need to be assembled. Attach washer only to end of the Carriage Bolt.
- ❖ Use **Allen Bolts or Hex Bolts** inserted through the **ROUND hole** on components that need to be assembled.
- ❖ Always wait until all bolts are assembled onto the equipment before tightening the bolts. Do not fasten each bolt right after it is installed

### Fasten Nuts and Bolts

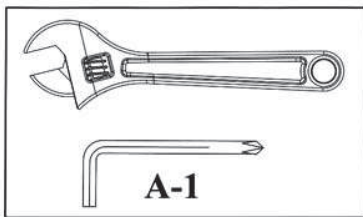

**Securely tighten all Nuts and Bolts after all components have been assembled in current and previous steps.**

**NOTE: Do not over tighten any component with pivotal function.**

**Make sure all pivotal components are able to move freely.**

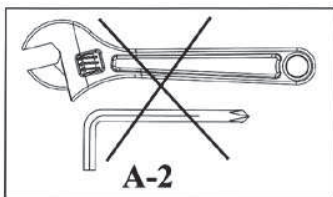

**Do not tighten all Nuts and Bolts in this step.**

### Seat Support (Part# 17) Assembly

The pivot on Seat Support needs to face when assembling the Seat Support.

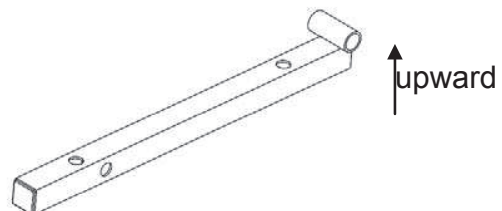



## CARE AND MAINTENANCE

1. Lubricate moving parts with WD-40 or light oil periodically.
2. Inspect and tighten all parts before using the equipment.
3. The equipment can be cleaned using a damp cloth and mild non-abrasive detergent. DO NOT use solvents.
4. Examine the equipment regularly for signs of damages or wear.
5. Replace any defective components immediately and/or keep the equipment out of use until repair.
6. **Failure to examine regularly may affect the safety level of the equipment.**

## Weight Capacity & Dimension

1. Maximum weight on Lever Arm: 500 lbs. (250 lbs on each Post)
2. Maximum weight on rear Weight Post: 400 lbs. (200 lbs on each Post)
3. Maximum weight on Weight Storage Post: 200lbs on each Post
4. Maximum user's weight on Bench: 350 lbs.
5. Assembled Dimension: 82" x 51" x 72"

## OPERATING NOTES

1. Use the Seat Incline Lock Pin (# 19) to select the Seat Incline.
2. Use the Lock Knob (#32) to select the Backrest Incline. Each hole increment will increase about 10 degree of incline.
3. \*Optional: Insert Leg Developer Holder into the opening in front of the Seat. Use the Lock Knob (#32) to hold the Holder in selected position. Use the Front Lock Pin (#17) to lock Leg Developer in place. Release the Front Lock Pin (#17) when doing Leg Developer exercises. **(Leg Developer sold separately)**
4. \*Optional: Insert Arm Curl Stand into the opening in front of the Seat. Use the Lock Knob (#32) to hold the Stand in selected position. **(Arm Curl sold separately)**

### Moving Bench Forward and Backward

1. Move Bench forward for flat, decline, and some incline positions. The rear position is for shoulder press and higher incline.
2. When using the Leg Developer, move back to have front stability without tipping when loading weight plates to Leg Developer.
3. When the Bench is not being used, it is stored in the rear position to save space.



## PARTS LIST

PART NO.	DESCRIPTION	SIZE	QUANTITY
1	Vertical Frame		1
2	Weight Storage Post		2
3	Lever Arm		1
4	Linkage Tube		1
5	Weight Post Frame		1
6	Lever Support Tube		2
7	Right Base Frame		1
8	Left Base Frame		1
9	Base Frame		1
10	Bench Base Frame		1
11	Front Stabilizer		1
12	Seat Main Frame		1
13	Backrest Support		1
14	Seat Linkage Bar		4
15	Backrest Adjustment Frame		1
16	Sliding Block		1
17	Seat Support		2
18	Seat Adjustment		1
19	Swivel Training Bar Bracket		1
20	Swivel Training Bar		1
21	Vertical Frame Diagonal Support		2
22	Leverage Adjustment Lock Pin		1
23	Seat Incline Lock Pin	Ø1" x 4"	1
24	Front Lock Pin		1
25	Axle	M12 x Ø 3/4" x 10 1/4"	1
26	Axle	M12 x Ø5/8" x 10 1/8"	1
27	Axle	M12 x Ø5/8" x 8 1/4"	1
28	Seat Pad		1
29	Backrest Board		1
30	T-shaped Lock Pin	M18	1
31	Grip		2
32	Lock Knob	M18	2
33	Linkage Tube Lock Pin		1
34	End Cap	2 3/8" x 2 3/8"	4
35	End Cap	3" x 3"	1
36	End Cap	2" x 2 3/4"	10
37	Sleeve	2 3/8" x 2"	1
38	End Cap	1" x 1"	4
39	End Cap	1 1/8" x 2 3/8"	4
40	End Cap	1" x 2"	1

41	Sleeve	1 1/8" x 2 3/8"	2
42	Olympic Sleeve	Ø2"	6
43	Clip	Ø2"	6
44	Grip	Ø1 1/4" x 23 3/4"	1
45	Grip	Ø1" x 20"	2
46	Grip	Ø 3/4" x 4"	2
47	Rubber Bumper	Ø 1 1/2" x 5/8"	1
48	Ball Bearing	6004	2
49	Hex Bolt	M12 x 4 1/8"	2
50	Hex Bolt	M12 x 3 3/4"	2
51	Hex Bolt	M12 x 4"	3
52	Hex Bolt	M12 x 3/4"	2
53	Hex Bolt	M10 x 1 5/8"	6
54	Hex Bolt	M12 x 3 3/8"	4
55	Hex Bolt	M12 x 3 1/8"	2
56	Hex Bolt	M12 x 2 3/8"	2
57	Hex Bolt	M12 x 6 3/4"	1
58	Hex Bolt	M12 x 6 1/8"	1
59	Hex Bolt	M12 x 6"	1
60	Hex Bolt	M10 x 5/8"	4
61	Philips Screw	M6 x 5/8"	1
62	Allen Bolt	M6 x 3/8"	1
63	Philips Screw	M4 x 1/4"	2
64	Hex Bolt	M10 x 3/4"	1
65	Aircraft Nut	M10	1
66	Aircraft Nut	M12	31
67	Washer	Ø 3/4"	11
68	Washer	Ø 1"	51
69	Large Washer	Ø 1" x Ø 3/8"	1
70	Metal Bushing	Ø 1" x Ø 5/8"	6
71	Metal Bushing	Ø 1" x Ø 1/2"	12
72	Metal Bushing	Ø 1 1/4" x Ø 5/8"	2
73	Seat Base Rubber Panel		1
74	Allen Wrench (Tool)	#4	1
75	End Cap	Ø 1"	1

# EXPLODED DIAGRAM

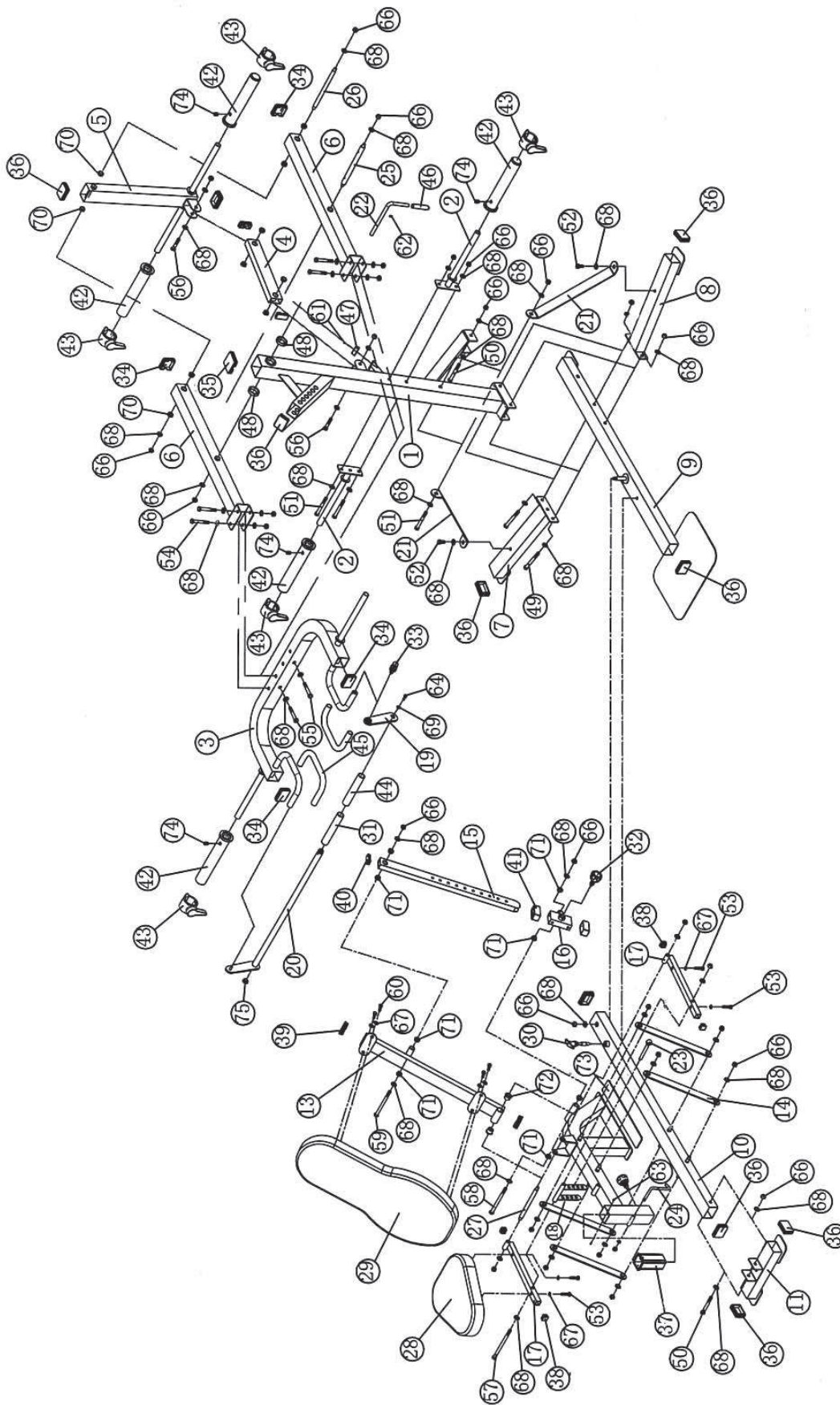

# **IMPEX<sup>®</sup> INC.**

## **LIMITED WARRANTY**

IMPEX Inc. ("IMPEX<sup>®</sup>") warrants this product to be free from defects in workmanship and material, under normal use and service conditions, for a period of two years on the Frame from the date of purchase. This warranty extends only to the original purchaser. IMPEX's obligation under this Warranty is limited to replacing or repairing, at IMPEX's option.

All returns must be pre-authorized by IMPEX. Pre-authorization may be obtained by calling IMPEX Customer Service Department at 1-800-999-8899. All freights on products returned to IMPEX must be prepaid by the customer. This warranty does not extend to any product or damage to a product caused by or attributable to freight damage, abuse, misuse, improper or abnormal usage or repairs not provided by an IMPEX authorized service center or for products used for commercial or rental purposes. No other warranty beyond that specifically set forth above is authorized by IMPEX.

IMPEX is not responsible or liable for indirect, special or consequential damages arising out of or in connection with the use or performance of the product or other damages with respect to any economic loss, loss of property, loss of revenues or profits, loss of enjoyments or use, costs of removal, installation or other consequential damages or whatsoever natures. Some states do not allow the exclusion or limitation of incidental or consequential damages. Accordingly, the above limitation may not apply to you.

The warranty extended hereunder is in lieu of any and all other warranties and any implied warranties of merchantability or fitness for a particular purpose is limited in its scope and duration to the terms set forth herein. Some states do not allow limitations on how long an implied warranty lasts. Accordingly, the above limitation may not apply to you.

This warranty gives you specific legal right. You may also have other rights which vary from state to state.

**Register on-line at [www.impex-fitness.com](http://www.impex-fitness.com)**

**IMPEX<sup>®</sup> INC.  
14777 Don Julian  
City of Industry, CA 91746**

### **ORDERING REPLACEMENT PARTS**

Replacement parts can be ordered by calling our Customer Service Department toll-free at **1-800-999-8899** during our regular business hours: Monday through Friday, 9 am until 5 pm Pacific standard time.

**[info@impex-fitness.com](mailto:info@impex-fitness.com)**

Please always provide the following information when ordering replacement parts.

1. Model
2. Description of Parts
3. Part Number
4. Date of Purchase

# IMPEX

F I T N E S S P R O D U C T S

## MARCY PRO Compact Gym PM-4400

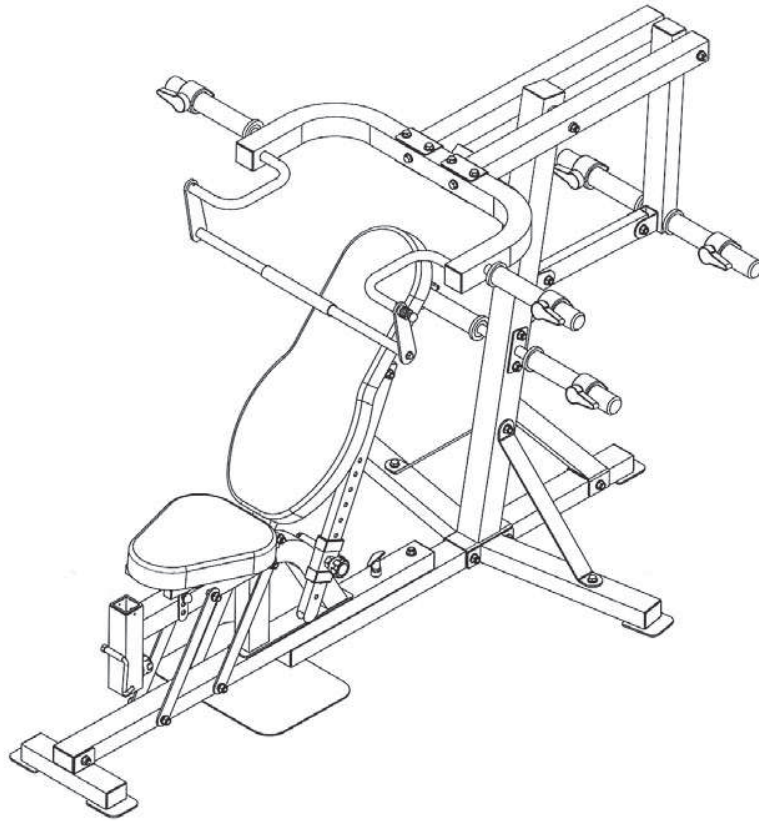

**IMPORTANT:** Please read the Important Assembly Information in the Owner's manual before assembling this product.

**Assembly Manual**

110509

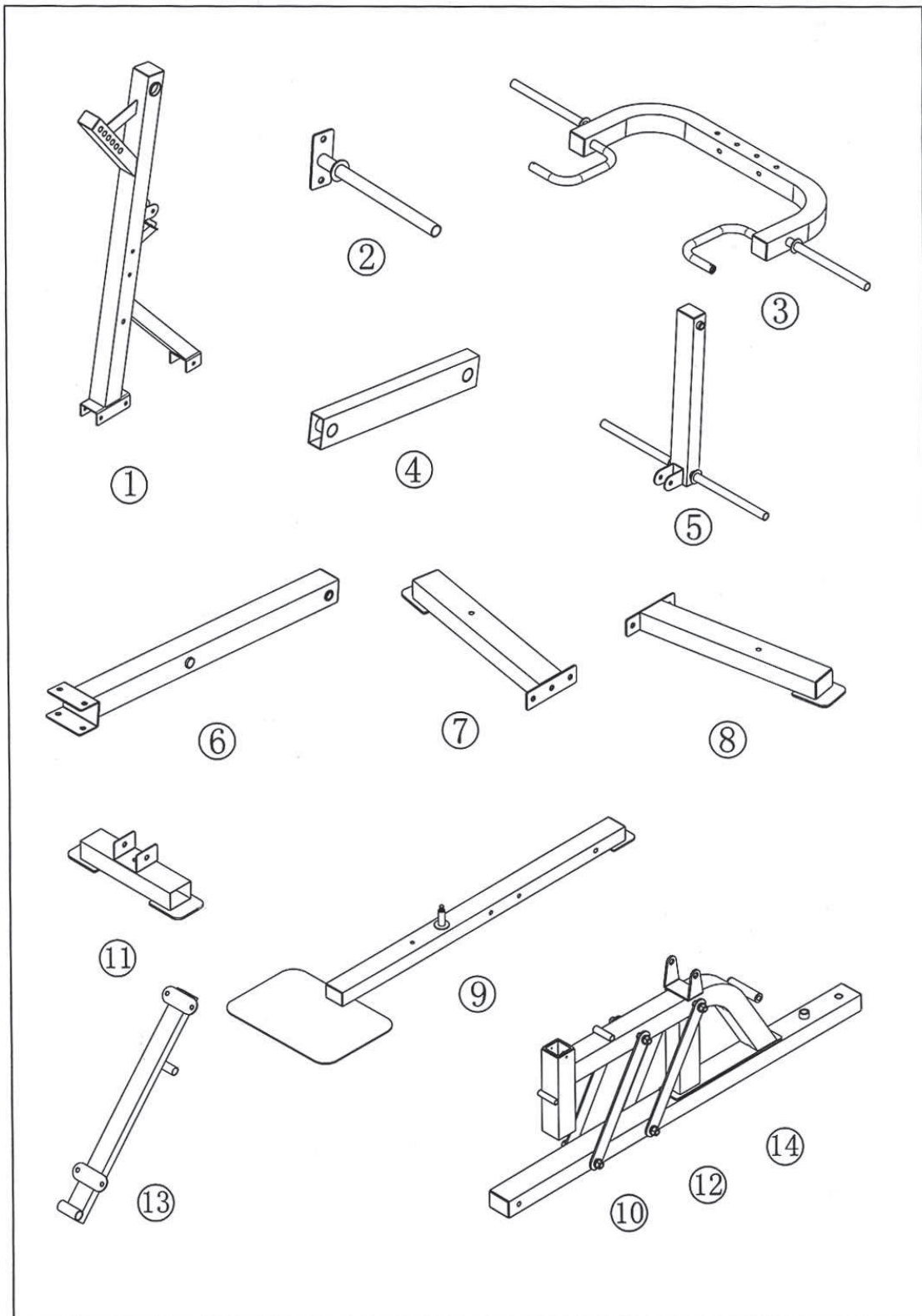



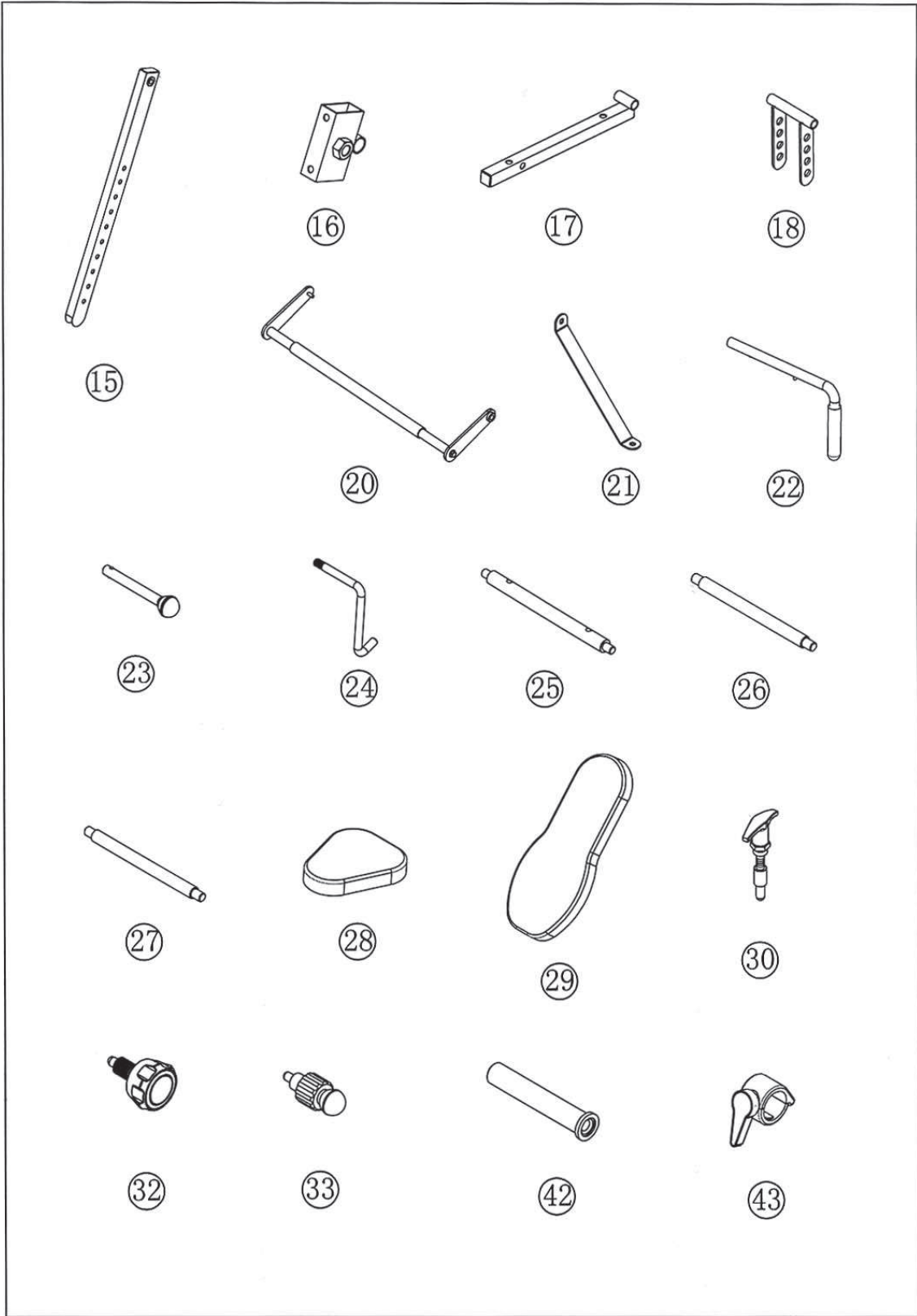



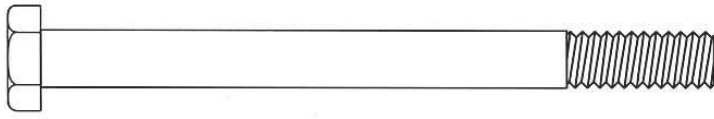

④9

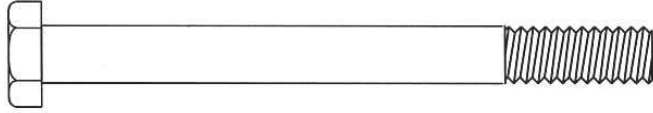

⑤0

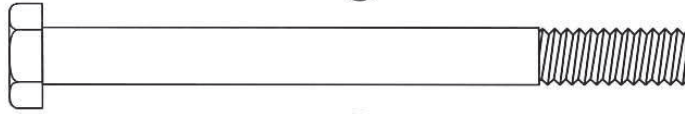

⑤1

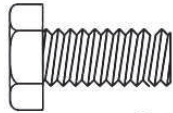

⑤2

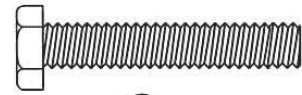

⑤3

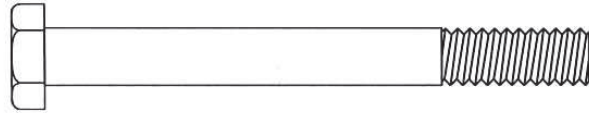

⑤4

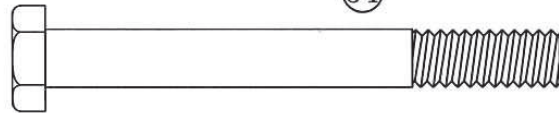

⑤5

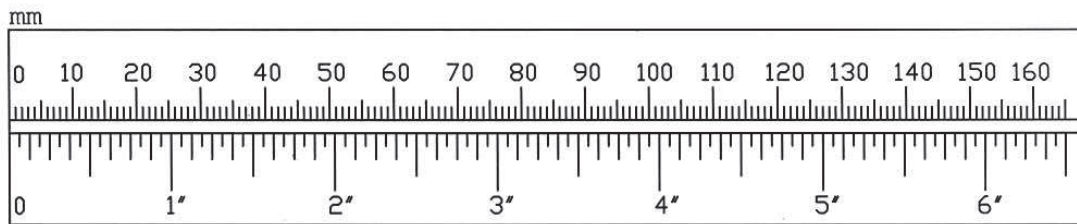

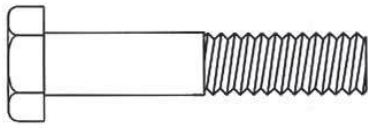

56

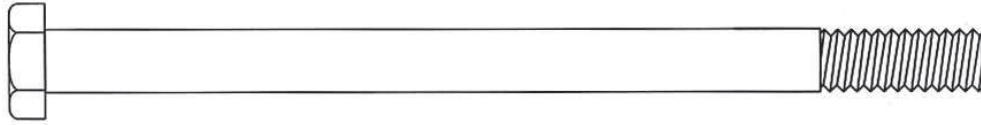

57

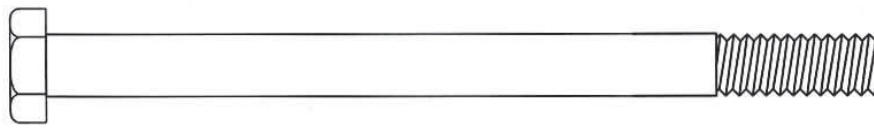

58

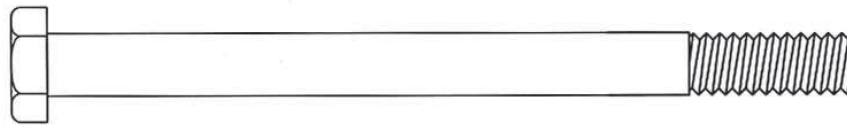

59

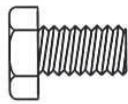

60

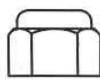

65

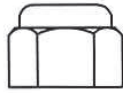

66

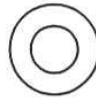

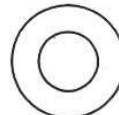

67



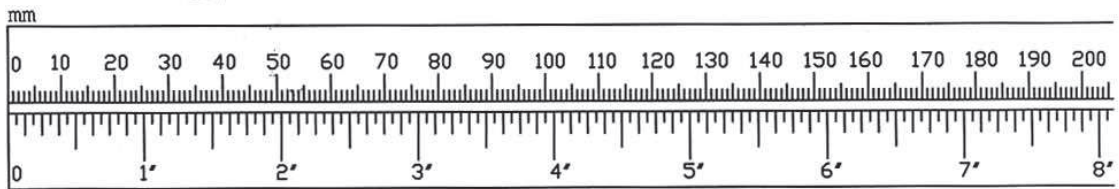
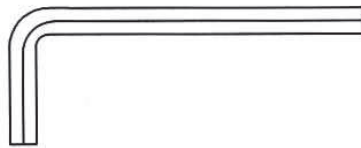

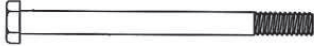
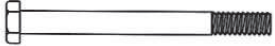

68

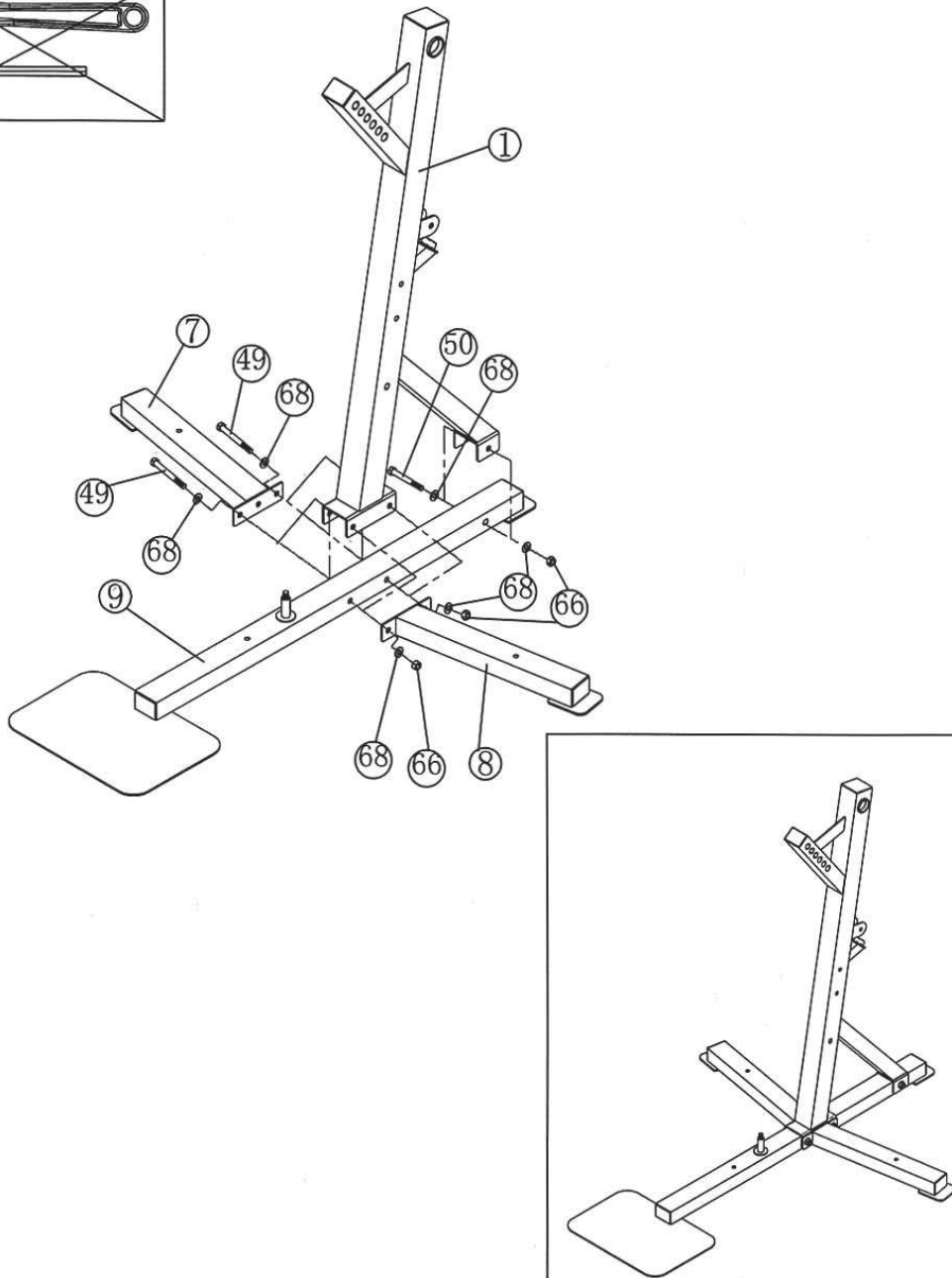
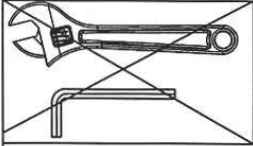

④9		2	M12 x 4 $\frac{1}{8}$ "
⑤0		1	M12 x 3 $\frac{3}{4}$ "
⑥6		3	M12
⑥8		6	Ø 1"

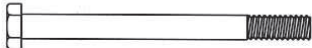

1

⑤1		1	M12 x 4"
⑤2		2	M12 x 3/4"
⑥6		1	M12
⑥8		4	Ø 1"

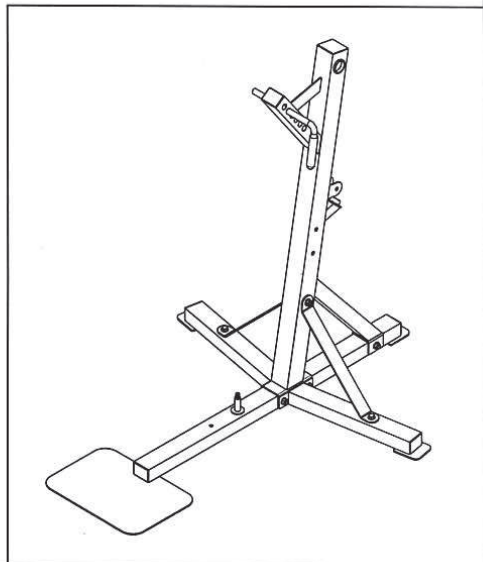
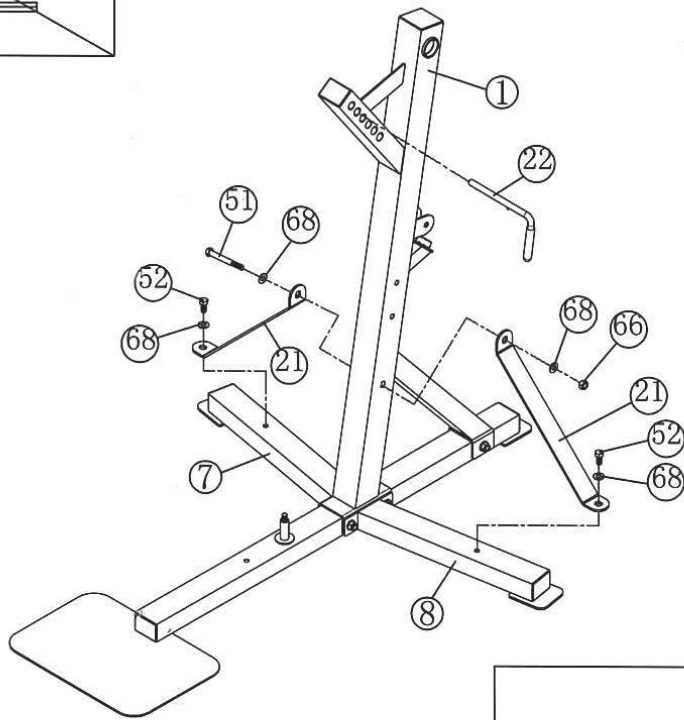
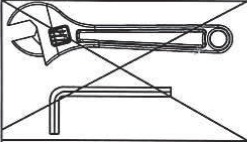

2



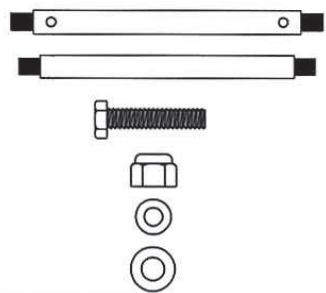

- 25
- 26
- 53
- 66
- 67
- 68

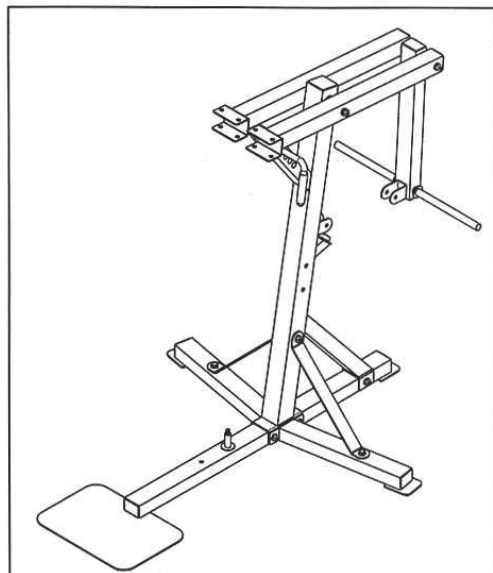
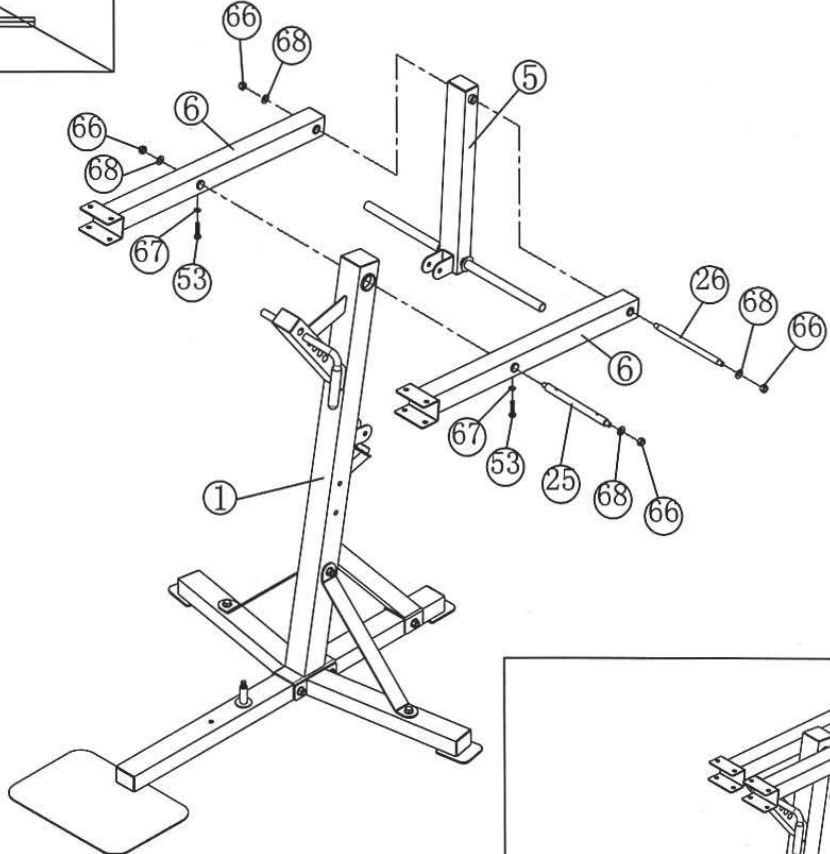
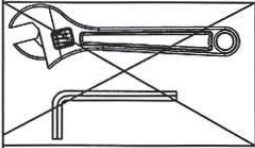

- 1 M12 x Ø 3/4" x 10 1/4"
- 1 M12 x Ø 5/8" x 10 1/8"
- 2 M10 x 1 5/8"
- 4 M12
- 2 Ø 3/4"
- 4 Ø 1"

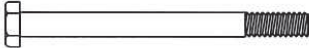

**3**

⑤4		4	M12 x 3 $\frac{3}{8}$ "
⑤5		2	M12 x 3 $\frac{1}{8}$ "
⑥6		4	M12
⑥8		10	Ø 1"

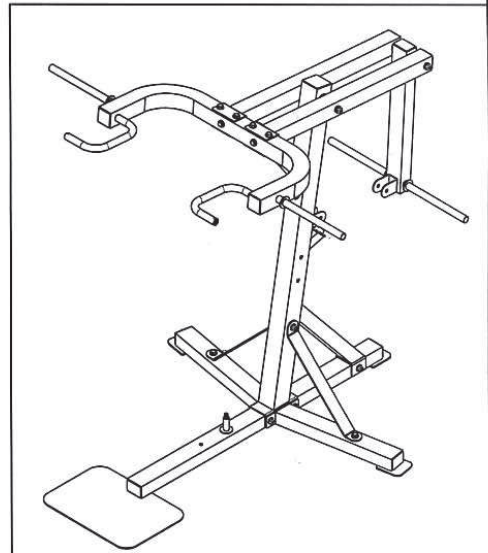
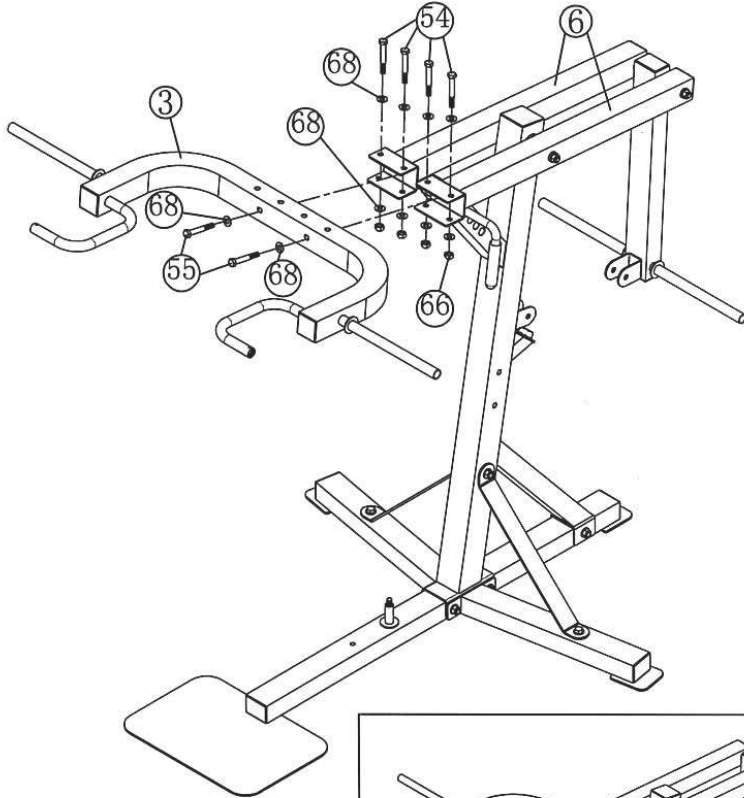
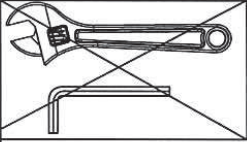

4



33



1

51



2

M12 x 4"

56



2

M12 x 3 <sup>3</sup>/<sub>8</sub>"

66



4

M12

68



8

Ø 1"

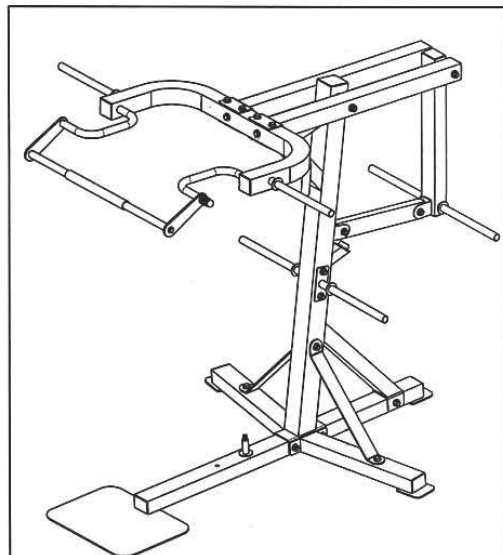
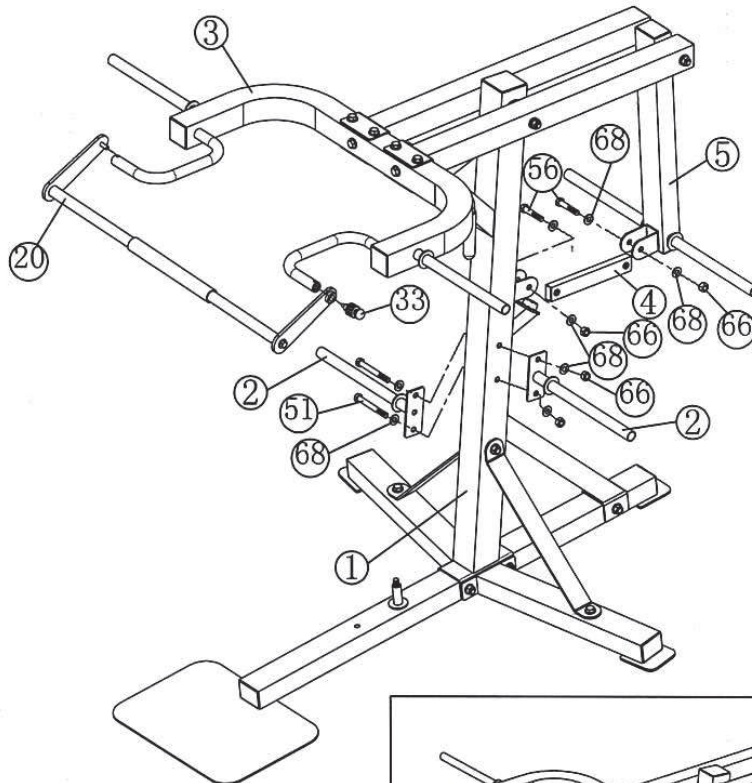
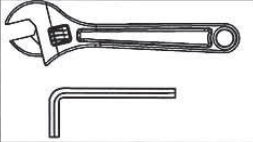

5



30



1

50

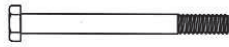

1 M12 x 3 3/4"

66



2 M12

68





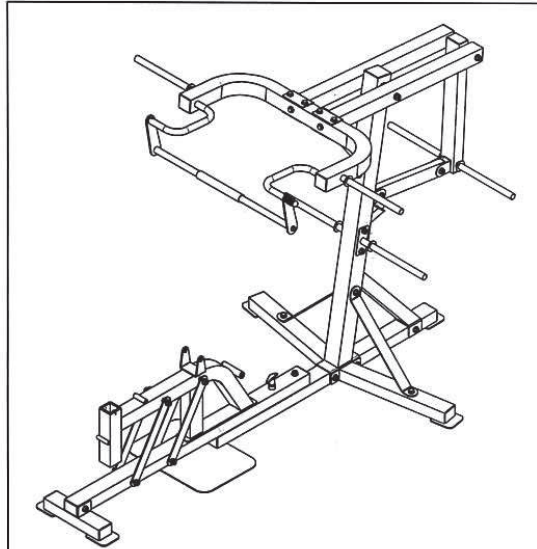
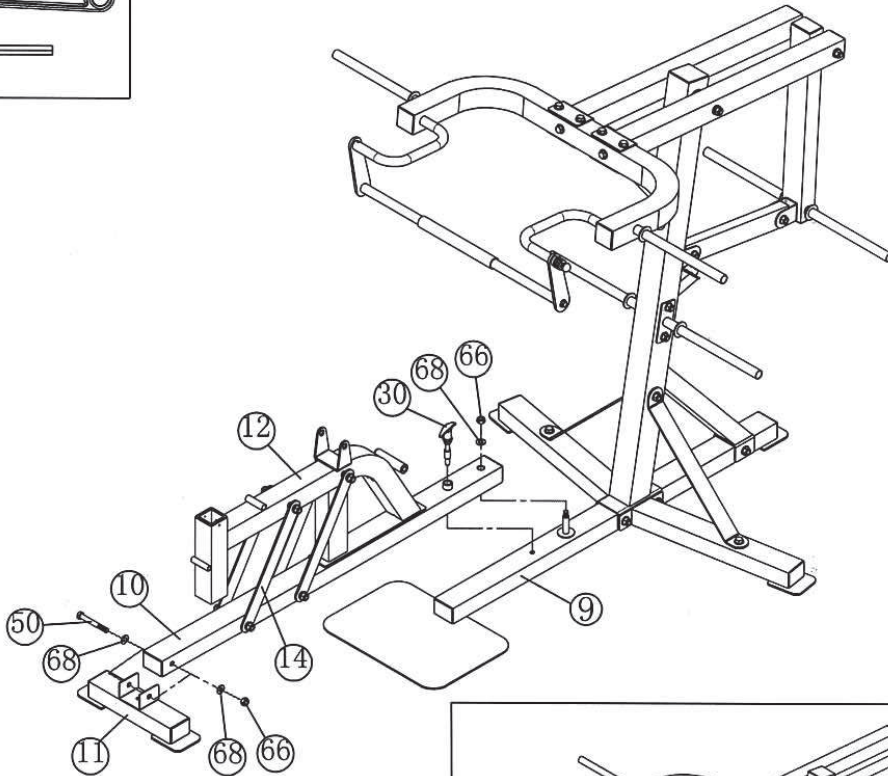
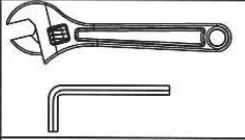

3 Ø 1"

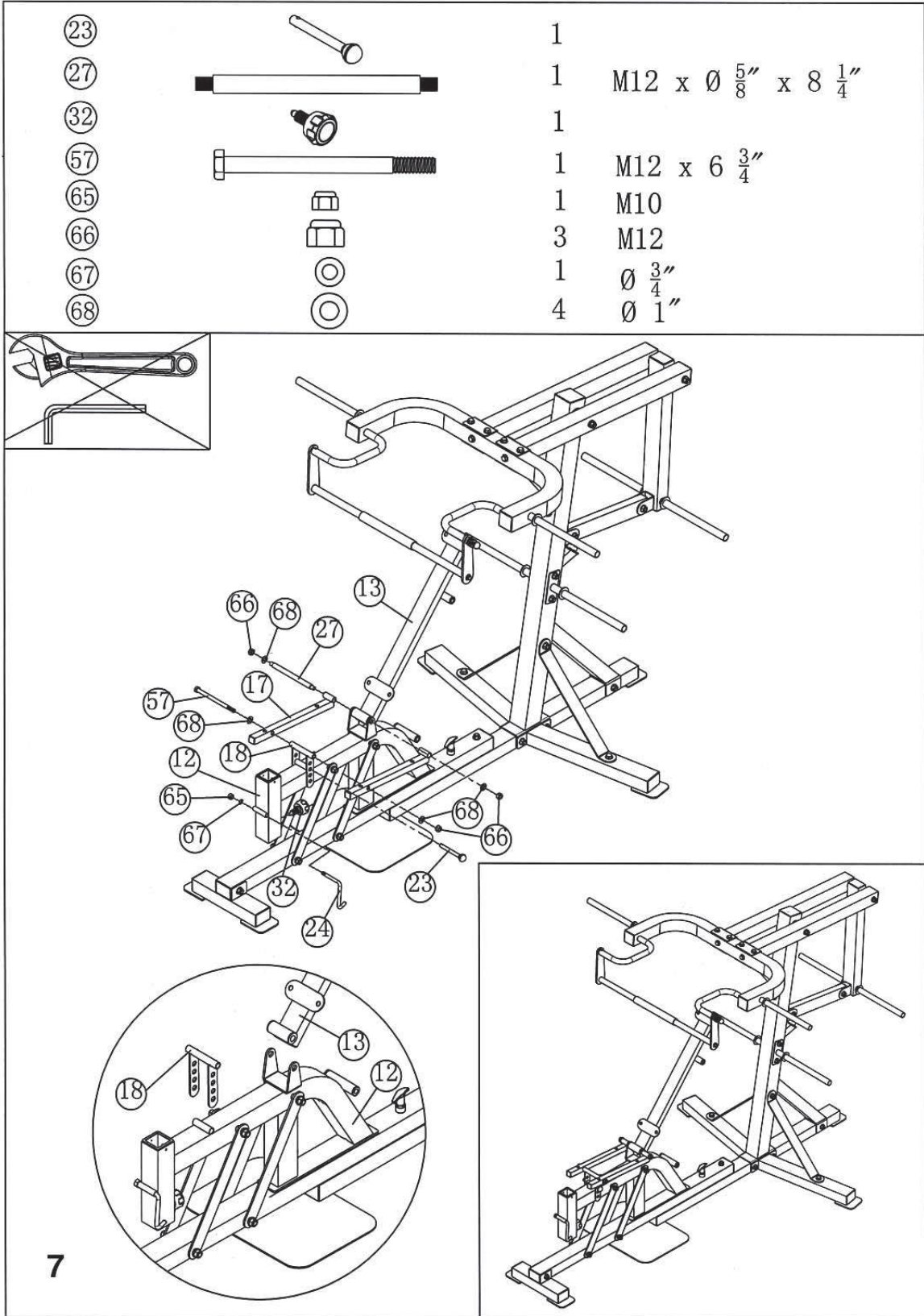

6



32		1
58		1 M12 x 6 $\frac{1}{8}$ "
59		1 M12 x 6"
66		2 M12
68		4 Ø 1"

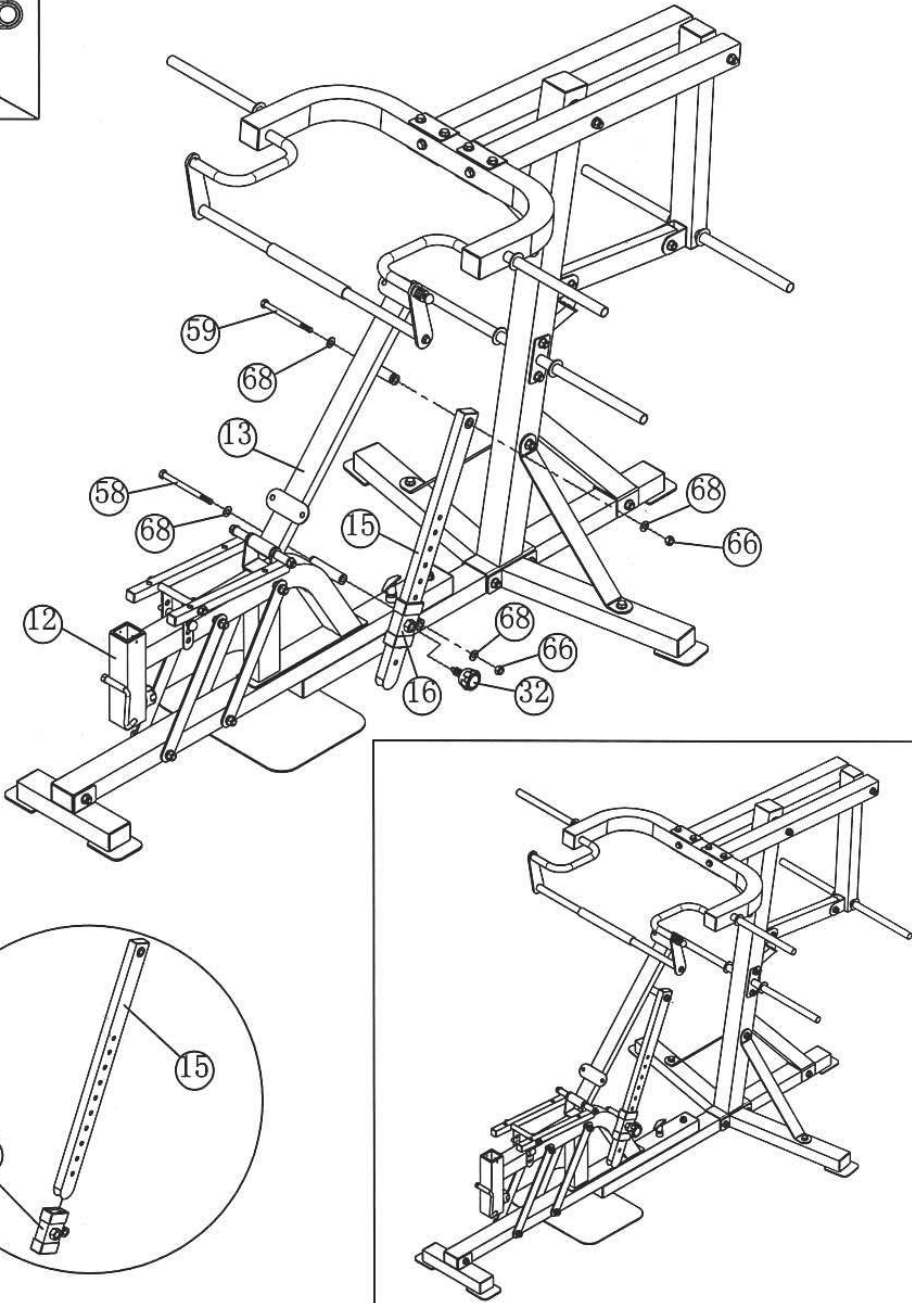
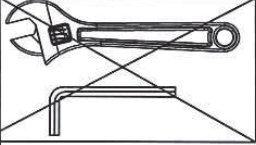

8

53



4 M10 x 1  $\frac{5}{8}$ "

60



4 M10 x  $\frac{5}{8}$ "

67



8  $\varnothing \frac{3}{4}$ "

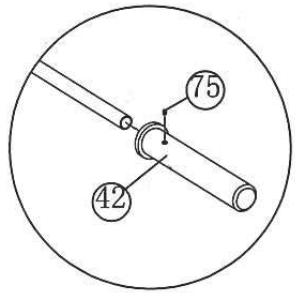
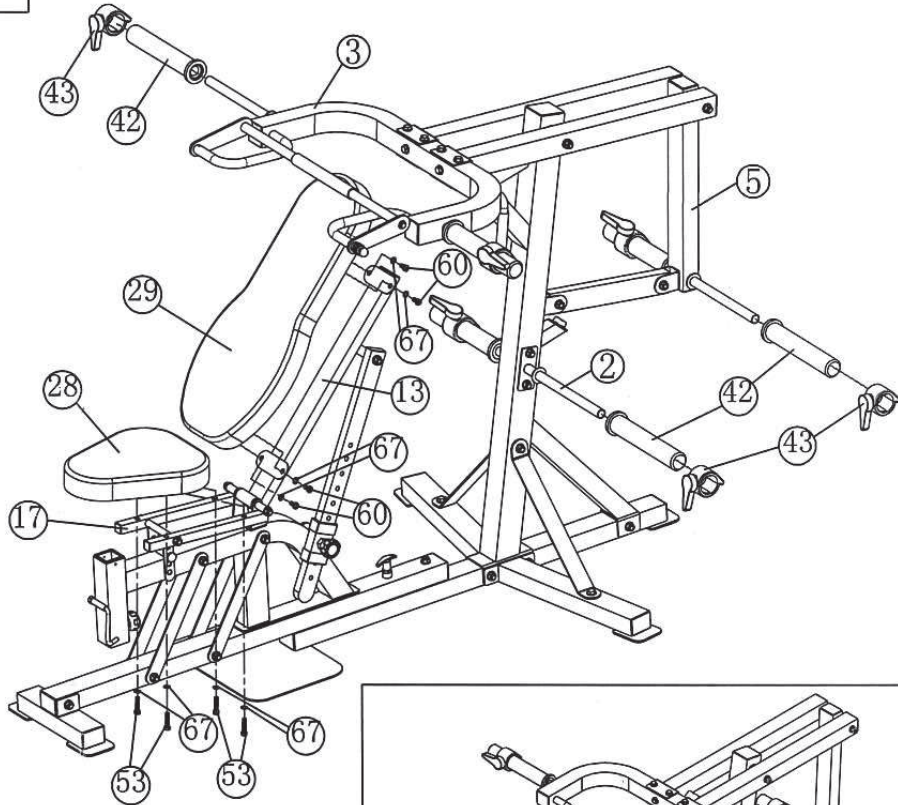
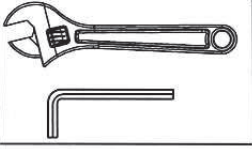

9

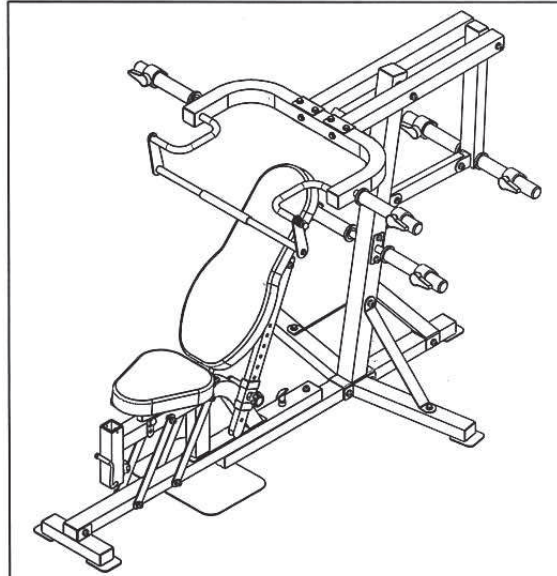



**IMPEX<sup>®</sup> INC.**

14777 DON JULIAN RD., CITY OF INDUSTRY, CA 91746

Tel: (800) 999-8899 Fax: (626) 961-9966

**[www.impex-fitness.com](http://www.impex-fitness.com)**

**[info@impex-fitness.com](mailto:info@impex-fitness.com)**